

WHEN POWER & PERFORMANCE MATTERS

CHOOSE ACTIVE

# AS50GW

SKID STEER  
SIT IN UNIT

## FEATURES

- 50HP Diesel Engine
- Tubeless Tyres
- 4 in 1 Bucket with Flat Face
- Couplings
- Simple Joystick Controls
- Heavy Duty Radiator / Oil Cooler
- Straight Forward Operation
- From Easy to Read Reference Panel
- Large Range of Attachments Available

## DIMENSIONS

A	Overall operating height(mm)	3980
B	Height to bucket hinge pin(mm)	3080
C	Height to top of cab(mm)	2140
D	Height to bottom of level bucket(mm)	2913
E	Without bucket length(mm)	2640
F	Overall length with bucket(mm)	3420
G	Dumping angle at maximum height (o)	40
H	Dumping height(mm)	2380
I	Dumping reach(mm)	700
J	Rollback of bucket on ground (o)	30
K	Rollback of bucket at full height (o)	104
L	Wheelbase(mm)	1075
M	Ground clearance(mm)	185
N	Angle of departure(o)	20
O	Front turning radius without bucket(mm)	1300
P	Front turning radius(mm)	2290
Q	Rear turning radius(mm)	1440
R	Rear axle to bumper(mm)	1080
S	Tread width(mm)	1450
T	Width(mm)	1720
U	Bucket width(mm)	1740

## ENGINE

Manufacturer	Xin chai
Model	C490BPG
Rated power(kw/)	36.7/2650
Engine displacement(L)	2.27
Emission standard	Tier two

## TECHNICAL PERFORMANCE

Operating weight (kg)	3100
Rated load (kg)	700
Bucket capacity (m3)	0.4
Max speed (km/h)	12
Max traction (kN)	≥25.40
Max breakout (kN)	≥18.4
Lifting time of boom(s)	7

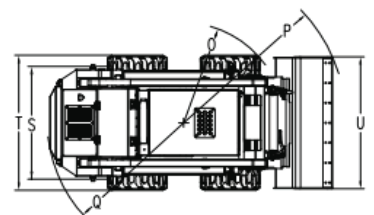
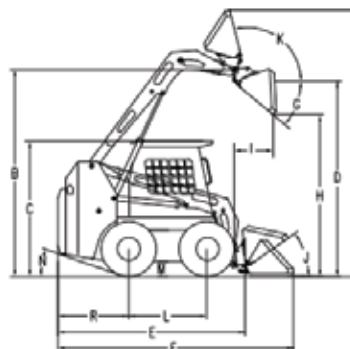

## PURCHASE PRICE

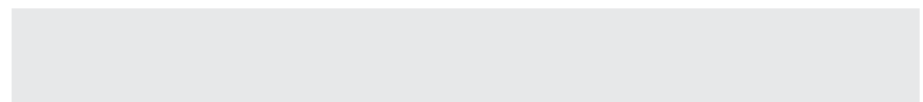

**ACTIVE MACHINERY**  
28-30 Hydrive Close  
Dandenong South Victoria 3175  
Phone 03 9799 7707  
Mobile 0409 307 500  
Email sales@activemachinery.com.au

www.activemachinery.com.au

Attachments Not Included. Due to continued advancements in technology, Active Machinery are constantly improving their quality range. Therefore the information and pictures shown should be used as a guide only.