



**WHEN POWER & PERFORMANCE MATTERS**

**CHOOSE ACTIVE**

# COMMANDO AM402DW

**MINI SKID  
STEER  
LOADER  
STAND ON UNIT**

## FEATURES

- ◆ 40HP Turbo Perkins Diesel Engine
- ◆ Donaldson Air Filter
- ◆ Simple Single Joystick Drive Control
- ◆ Straight forward operation from the easy to read reference panel
- ◆ Easy access to service and maintenance compartments
- ◆ Rubber Tracked or Rubber Tyre models available
- ◆ Large Range of Attachments Available: Pallet Forks, Trenchers, Augers, Slashers, Mini hoe etc

### DIMENSIONS

A Maximum Working Height	2710 mm
B Maximum Pin Shaft Height	2,105 mm
C Maximum Unloading Height	1,655 mm
D Highest Point Unloading Distance	505 mm
E Height	1,620 mm
F Aboveground Height	186 mm
G Wheelbase	769 mm
H Overall Length (with bucket)	2,702 mm
I Length (without bucket)	2,075 mm
J Total Width	1,070 mm
K Bucket Width	1,170 mm
Tyre Size	23 X 8.50 -12 NHS
Bucket Angle	55 °
Bucket Unloading Angle	35 °
Tilt Angle	30 °

### ENGINE

Model	Perkins Turbo
Rated Power	(40HP)
Rotating Speed	2,400rpm
Electrical	12 Volt / Alternator
Fuel Tank Capacity	35L
Noise	≤ 95dB

### TECHNICAL PERFORMANCE

Rated Load	400kg (4 in 1 Bucket)
Operating Weight	1,400kg (INC 4 IN 1 Bucket)
Bucket Capacity	0.2m <sup>3</sup>
Max Lifting Capacity	600kg (with added Counter weights)
Max Travel Speed	0-12 km/h

### HYDRAULIC SYSTEM

System Pressure	3625 PSI (250 Bar)
Hydraulic Oil Capacity	35L
Hydraulic Valve	Hydro Control Joystick (Italian)
Hydraulic Pumps	Hansa TMP (Italian) x3
Flow	50 L/Min 170 bar at couplings
Cooler	Alloy Radiator

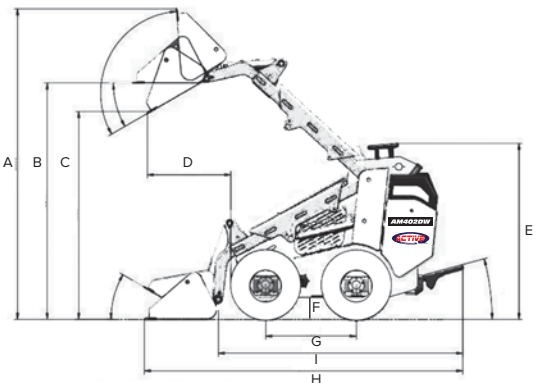
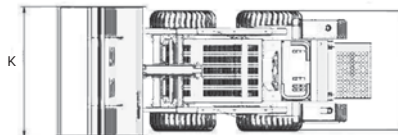

**ACTIVE MACHINERY**  
28-30 Hydrive Close  
Dandenong South Victoria 3175  
Phone 03 9799 7707  
Mobile 0409 307 500  
Email sales@activemachinery.com.au

### PURCHASE PRICE

Attachments Not Included. Due to continued advancements in technology, Active Machinery are constantly improving their quality range. Therefore the information and pictures shown should be used as a guide only.