

WHEN POWER & PERFORMANCE MATTERS

CHOOSE ACTIVE

COMMANDO AM230PW

MINI SKID STEER LOADER STAND ON UNIT



FEATURES

- ◆ 23HP Honda GX690 Engine
- ◆ Option of Single joystick or Twin Joystick Operation
- ◆ Straight forward operation from the easy to read reference panel
- ◆ Easy access to service and maintenance compartments
- ◆ Rubber Tracker or Rubber Tyre models available

Large Range of

Attachments Available:

General Purpose Buckets, Forks, Trenchers, Augers, etc

With a length of 2190mm and a width of just over 1m this little Commando is sure to be beneficial to your business' small access applications.

DIMENSIONS

A Maximum Working Height	2,260 mm
B Maximum Pin Shaft Height	1,840 mm
C Maximum Unloading Height	1,380 mm
D Highest Point Unloading Distance	510 mm
E Height	1,380 mm
F Aboveground Height	105 mm
G Wheelbase	750 mm
H Overall Length (with bucket)	2,190 mm
I Length (without bucket)	1,730 mm
J Total Width	1,140 mm
K Bucket Width	1,150 mm
Bucket Angle	55°
Bucket Unloading Angle	33.7°
Tilt Angle	30°

HYDRAULIC SYSTEM

System Pressure	180 Bar
Hydraulic Oil Capacity	30L
Hydraulic Pump	USA PERMCO HP Pump, 60L/min, 21 MPa (3,045psi) @ 3000rpm

ENGINE

Model	Honda GX690
Rated Power	17.2kW (23HP)
Rotating Speed	3,600rpm
Fuel Tank Capacity	23L
Noise	≤80

TECHNICAL PERFORMANCE

Rated Load	200kg (4 in 1 Bucket)
Operating Weight	1,080kg (INC 4 IN 1 Bucket)
Bucket Capacity	0.15m ³
Maxi Lifting Capacity	400kg (with added Counter weights)
Max Travel Speed	0-6.5km/h

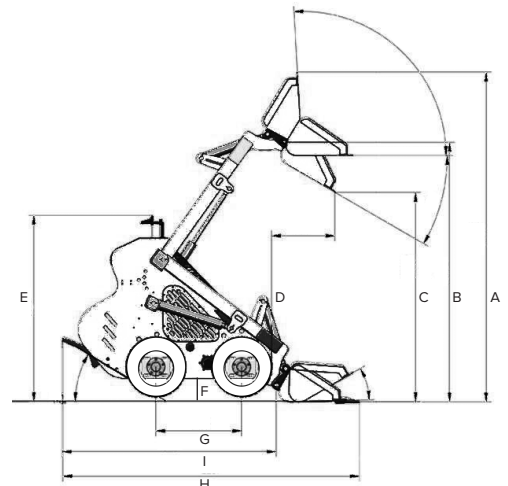
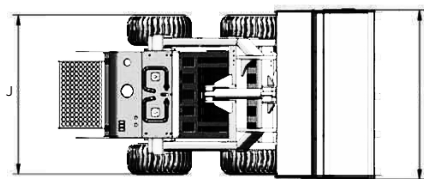

PURCHASE PRICE



ACTIVE MACHINERY
 28-30 Hydrive Close
 Dandenong South Victoria 3175
 Phone 03 9799 7707
 Mobile 0409 307 500
 Email sales@activemachinery.com.au

www.activemachinery.com.au

Attachments Not Included. Due to continued advancements in technology, Active Machinery are constantly improving their quality range. Therefore the information and pictures shown should be used as a guide only.